

A view of the city of Kabul

SOCIETY OF
AFGHAN
ENGINEERS

QUARTERLY
eNEWSLETTER



CELEBRATING
10 YEARS OF
CONTINUOUS
SUCCESSFUL
PUBLICATION



SAE eNEWSLETTER

VOLUME 13, ISSUE 2

HAMAL 1402

APRIL 2023

SAE MISSION

TO PRESENT A FORUM FOR AFGHAN ENGINEERS, ARCHITECTS AND SCIENTISTS IN THE SHARING OF EXPERIENCES AND KNOWLEDGE AND FOSTER THE PROMOTION OF SCIENTIFIC, ARCHITECTURAL AND ENGINEERING ETHICS IN OUR QUESTS TO ENHANCE AFGHAN CAPACITIES IN THESE FIELDS FOR THE SERVICE OF AFGHANISTAN AND THE WELL BEING OF THE PEOPLE.



SAE eNEWSLETTER

Volume 13, Issue 2

Hamal 1402

April 1, 2023

P.O Box 151584 Alexandria, VA 22315 USA

<http://www.afghanengineers.org>

CONTENTS

Editor's Note	3
Message From the President of SAE	5
Message from the Chairman of the SAE Board of Directors	7
SAE Executive Action No. 33, March 14, 2023,	8
SAE Executive Report No. 28, March 6 , 2023,	14
SAE Executive Action No. 29, March 7, 2023,	17
SAE Executive Action No. 30, February 9, 2023,	18
Design of Modern Digital Electronic Systems	19
Kabul City Ground Water Aquifer Storage and Recovery	28
Life of the Late Professor Abdullah Breshna	34
Membership News	37
Opportunities at Planate Management	43
Comments and Suggestions	46
The SAE Membership Renewal	50
Membership Applications	52/53

Note From the Editor-in-Chief, SAE eNewsletter



Thank You to The Readers of SAE

It has been a privilege and honor being the Editor-in-Chief of the eNewsletter, of the Society of Afghan Engineers (SAE), a member of the Editorial Board, and a two terms member of the Board of Directors, always working toward noble objectives of the SAE to help our beloved homeland Afghanistan and to serve the Afghan Engineering community. The Society of Afghan Engineers is a non-profit organization, being an SAE member, the role as Board Director and eNewsletter Editor-in-Chief, and committee assignments are volunteer responsibilities.

In addition to my regular full-time job, and SAE membership responsibilities, I have been working on writing engineering textbooks with (Mohtarem Dr. Zarjan Baha), for the students at Afghan Universities. Our first textbook was published in three volumes in 2021 and 2022, in Kabul (<https://ecampus-afghanistan.org/>), it is being used as a Structural Analysis textbook by the Universities inside Afghanistan. I must focus and spend more time on completing the second textbook, currently in progress, to make it ready for publication and distribution to the Afghan Universities on time.

With these additional commitments, I can no longer continue with the Editor-in-Chief responsibility, and I am resigning from the role of the Editor-in-Chief of the Society of Afghan Engineers eNewsletter. It is time that the younger generation carries this responsibility with vigor and brings innovations for improving the technical content of the eNewsletter. I also propose the eNewsletter should move to the SAE website, where it can be updated and maintained efficiently.

I am extremely thankful to Allah for providing me with this volunteer undertaking, an opportunity for helping our beloved homeland Afghanistan and serving the Afghan Engineering community. I would like to thank all those readers who provided their valuable feedback and comments. I also would like to thank those members who provided technical papers, their contribution is appreciated. Lastly, I want to thank the members of the Editorial Board for their hard work and support in making the newsletter ready for publication on time. The Society under the leadership of Mohtarem Najim Azadzoï and Mohtarem Manan Khalid has made SAE a world-known organization. Architects/Engineers in Afghanistan, China, Indonesia, Saudi Arabia, Arab Emirates, and several other nations around the globe now know and talk about the Society of Afghan Engineers of the USA.

We are at the start of the year 1402, and the holy month of Ramzan, I am humbly requesting the Afghan authority in charge in Afghanistan, to end the ban on schools and universities for Afghan girls. I am urging the authorities to permit education for girls' students without any further delay. Closure of educational institutions for girls is unacceptable and it is not in according with the teaching of Islam.

I wish each one of you and your respected family a happy, healthy, and prosperous year 1402 and beyond. We ask Allah Almighty to prevail in peace, prosperity, and re-opening of high school and university level education for schoolgirls in our beloved homeland Afghanistan. I wish each one of you and your respected family a happy and healthy holy month of Ramzan.

Thank you again for your support.

With Warm Regards,

Hafizullah Wardak

hwardak@comcast.net

Editor- in- Chief SAE eNewsletter
and Chairman - SAE eNewsletter Subcommittee

SAE Society of Afghan Engineers

Message From the President of SAE January 2023



Members of the Society of Afghan Engineers

Ramazan is a time to become closer to God. It is also a time for prayers and giving charities to those in need.

“Ramazan Mubarak”

We also observed the celebration of Nowruz 1402 on March 21, 2023. May this year bring new joy, new objectives and accomplishments and a lot of new motivations. Wishing you a happy and prosperous year.

“Nowruz Mubarak”

The Society is making progress toward its goals set up before the beginning of 2023:

- Membership of the Society continues to grow. We have new Afghan engineers and architects from the USA and Afghanistan who joined the Society. We have three new members; Dr. Hashmatullah Atmar from Kabul, Mr. Fayeque Fasisi from Virginia, and Mr. Abdul Bari Mammandi from Kabul. Several other former members rejoined the Society within these past few months. I welcome all of them and look forward to their contribution to the Society.
- The Bamiyan International Students Housing Competition team, headed by Professor Bashir Kazimee, completed the selection of finalists.
 - The first-place winner is a woman student architect from the Liverpool University of China. The second-place winners are three women architecture students from the University of Sebelas Maret of Surakarta, Indonesia and, the third-place winners are one woman student and two men students from the Najjing Tech University of China. My congratulations go to all the winners and particularly to the women architecture students dominating the competition.
 - The five Jurors, highly qualified architecture scholars and educators from around the world, were Dr. Daniela Ottmann an Associate Professor from Bond University in Australia, Lalith Lankatilleke from UN Habitat, and Dr. Samia Rab Kirchner an Associate Professor of Urban Design from Morgan State University in Baltimore, Maryland. Two of the Jurors were from the SAE, Professor Reinhard Goethert of MIT and Professor Rafi Samizay. The Jurors, after three zoom meetings and deliberations, selected the first, second, and third place winners. Also, the Jurors decided to award six other teams as Honorary winners to appreciate their quality of design and participation in the competition. I, on behalf of the Society, would like to thank all the Jurors for their volunteer work and times and excellent reviewing of 24 projects submitted.

- It is with much joy and happiness to find that one of the six Honorary winners is, a team of four young women architecture graduates from Kabul University. Congratulations to all four Afghan women architects.
- Certificates have been provided and the team is in the process of distributing the cash prizes.

SAE Election 2023 is underway. I nominated Mr. Atiq Panjshiri to chair the election committee, as per the Bylaws of the Society, and his nomination was accepted by the Board of Directors. Also, in accordance to the Bylaws of the Society, four members are needed to serve in the election committee. Dr. Saleh Keshawarz, Mr. Qaseem Naimi, Mr. Nazir Babacarkhial, and Mr. Fayege Fasihi were nominated to the committee and their nominations were approved. I thank and wish the election committee members success and look forward to a clear and transparent election process as per the Bylaws of the Society.

The Society, in collaboration with Engineer Feda of Afghan Education for Better Tomorrow (AEBT), will jointly provide online training sessions on a variety of engineering topics to Universities in Afghanistan. AEBT signed an MOU with the Faculty of Engineering in Kabul University.

We also look forward to having a wonderful SAE General Assembly Meeting this year. Due to Covid-19 restrictions, the past two General Assemblies in 2021 and 2022 were held virtually. We hope this year we are able to arrange a face-to-face gathering of all members and SAE friends and colleagues in a place that will be designated later.

With Regards,

Najim M. Azadzoi, AIA

SAE President

Message From the Chairman, SAE Board of Directors



Dear Readers of the SAE ENewsletter

A Professional society (also called a professional body, professional organization or a professional association) is formed to organize professionals of a single or multiple fields to further a particular profession and to serve certain mission. Most are **501(c)(3) nonprofit organizations** with their sole goal of service to a profession or a cause. Nonprofit means that the entity is organized for a nonprofit purpose and has been recognized by the Internal Revenue Service (IRS) as being tax-exempt by virtue of its charitable programs. Such organizations are eligible to receive tax-deductible contributions provided that no part of the gathered funds are used for personal use by any private entity or by those involved in them.

A good example of such organization is the American Society of Civil Engineers (ASCE). According to their website, it was founded in 1852, which makes it the oldest society in America. It has about 150,000 members from 177 countries. Its membership fee is age based and for persons 29 years or older, the current membership fee is \$255 per year. Due the large number of members and other funding opportunities, it can afford to abide by its mission.

As it is clear from the example above, societies thrive on their members. The more the members, the wider the service base and the more the budget and fundraising capabilities. Society of Afghan Engineers (SAE) being such an organization has not been able to attract and keep enough members. Limited membership affects its budget and poses other challenges too. Among other things, it creates a challenge for future elections. Limited membership shows lack of interest and clearly jeopardizes the future of our Society. With the noble mission of volunteer service to our country and people, it is incumbent for more of us to become active members.

Spring is in the air and so is the election for the next administration at the Society of Afghan Engineers. By the time of the publication of this issue, the election committee comprised of a chairman and four members will be in place. They will kick start the elections. However, as past is the witness, due to limited membership, their biggest challenge will be finding nominations for the future administration. It will be ideal if more of our young professionals get involved and take charge this time. With fresh minds and endless energy, they will keep the flames burning and will lead this Society into a bright future. The goal is to serve our country and our people.

Happy New Year!

Sincerely,

Abdul Manan Khalid, P.E., LEED (BD+C)

Chairman, SAE Board of Directors

SAE Society of Afghan Engineers



SAE Executive Action No. 33, March 14, 2023

AN UPDATE ON BAMMIYAN HOUSING

DISTRIBUTION OF THE AWARDS AND CERTIFICATES

Brief of the Bamiyan SAE International Student Design Competition - Final Phase

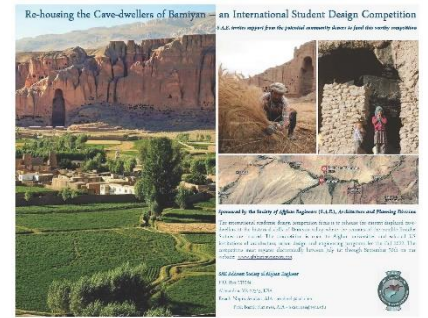

On behalf of the Bamiyan International Student Competition Committee, we are pleased to inform you that the jurors for the Bamiyan International Student Design Competition have completed their evaluation of the competition proposals from around the world and the winners are publicly announced.

We have received twenty-three entries from eleven universities around the world, including three Afghan universities. After careful deliberation and evaluation of the entries, based on the “criteria for evaluation,” the jury has selected the top three projects for the first, second and third prizes. In addition, they have recommended six projects for honorable mention. All the winners will receive a cash prize noted in the competition brief and SAE- Certificate of Achievement.

We want to express that both the competition organizer committee and the jury members were remarkably impressed with the quality, thoughtfulness, and effort that students devoted to their proposals. We want to congratulate all the winners, their selection was based on careful consideration, and quality of their proposals.

The award money is supported by the generous donations of the Kazimee Family charity Funds and Toba Roshan Education Funds. We want to extend our sincere gratitude to them for funding this important cause.

The following chart represent the top three winners and the six honorable mentions:

Project Code	Grade	University, Student and Advisors Names	Award Amount
Top Winners			
6 B	1st Place	University: Xi'an Jiaotong – Liverpool University: Department of Architecture Student: 1. Kaiqing Tan Faculty advisor: Prof. Gergely Csikvari China	\$2500
12A	2nd Place	University: Universitas Sebelas Maret of Surakarta: Department of Architecture/Engineering Student Team 1. Trevi Marisa 2. Adesti Ulfatun Nisa 3. Yulita Devina Faculty advisor: Dr. Eng. Kusumaningdyah Nurul Handayani Indonesia	\$1,500

10A	3rd Place	<p>University: Nanjing Tech University:</p> <p>Dept. of Architecture and Urban Design</p> <p>College of Architecture</p> <ul style="list-style-type: none"> • Student Team: <ul style="list-style-type: none"> ○ 1. Yuxing WU ○ 2. Yang ZHANG ○ 3. Tianyi CHEN <p>Faculty advisor: Prof. Dr. Longbin Zhu</p> <p>China</p>	\$1000
-----	---------------------------------	---	--------

Honorable Mentions

4A		<p>University: American University of Sharjah:</p> <p>Department of Architecture</p> <p>Student Team:</p> <ol style="list-style-type: none"> 1. Zainab Oghai Gawhari 2. Razan Nabil Almajid 3. Ahmad Khalil Ammar 4. Ranya Aysha 5. Rabab Al-Ali <p>Faculty advisor: Prof. George Newlands</p> <p>UAE</p>	\$300
----	--	---	-------

4C		<p>University: American University of Sharjah:</p> <p>Department of Architecture</p> <p>Student Team:</p> <ol style="list-style-type: none"> 1. Nada Hani Barqawi 2. Meera Tareq Lootah 3. Mrinaalini Nagaraja 4. Tala Alsakka-Amini 5. Sabiha Ameen <p>Faculty advisor: Prof. George Newlands</p> <p>UAE</p>	\$300
6A		<p>University: Xi'an Jiaotong – Liverpool University:</p> <p>Department of Architecture</p> <p>Student:</p> <ol style="list-style-type: none"> 1. Shuyang Li <p>Faculty advisor: Prof. Gergely Csikvari</p> <p>China</p>	\$300
1A		<p>University: Kabul University</p> <p>Architecture Department</p> <p>Student Team:</p> <ol style="list-style-type: none"> 1. Hoda Amini 2. Lima Hamza 3. Diana Anwaeri 4. Salma Sharif <p>Faculty advisor: Naweed Ahmad Hashemi</p>	\$300

		Afghanistan	
5A		<p>University: University of Hartford:</p> <p>Department of Civil, Environmental, and Biomedical Engineering</p> <p>Student:</p> <p>1. Vivek Parek</p> <p>Faculty advisor: Prof. Stephen Charles Smith</p> <p>USA</p>	\$300
13C		<p>University: Effat University:</p> <p>Collage of Architecture and Design</p> <p>Student Team:</p> <p>1. Sabeen Alharthi</p> <p>2. Lina S. Abouelnaga</p> <p>Faculty advisors: Dr. Yassmein H. Abdalla & Ms. Majd Alnafie</p> <p>Saudi Arabia</p>	\$300

Jury members

1. Dr Daniela Ottmann: Associate Professor, Centre for Comparative Construction Research, Bond University, Australia.
2. Samia Rab Kirchner, PhD: Associate Professor of Urban Design and Interim Chair, Morgan State University, Baltimore, MD, USA
3. Joseph Ashmore: *Senior Emergency Post Crisis Partnerships Specialist*, International Organization for Migration, Washington DC., USA

4. Professor Rafi Samizay, AIA: Professor Emeritus, Washington State University, School of Architecture and Construction Management, USA.
5. Dr. Reinhard Goethert : MIT, School of Architecture, Cambridge, MA 02139, USA

Once again, on behalf of the Society of Afghan Engineers (SAE) and the Competition Organizer Committee, we want to extend our sincere gratitude to the respected jury members for their hard work and careful deliberation to review and select the winning projects for the Bamiyan International Student Design Competition.

Sincerity,

Bashir Kazimee, AIA
 Professor Emeritus, Washington State University
 Chairperson: SAE-Architecture and Planning Division

Competition Organizer Members:

- Najim Azadzoï, SAE President
- Professor Mehdi Sabet
- Professor Rafi Rafi Samizay
- Professor Reinhard Goetherd
- Donya Amiri, PE, TE
- Professor Bashir Kazimee (Chair)

Najim Azadzoï, AIA. SAE President.

Re-housing the Cave-dwellers of Bamiyan - an International Student Design Competition
S.A.E. invites support from the potential community donors to fund this worthy competition

Sponsored by the Society of Afghan Engineers (S.A.E.), Architecture and Planning Division

The international academic design competition focus is to rehouse the current displaced cave-dwellers at the historical cliffs of Bamiyan valley where the remains of the notable Buddha Statues are located. The competition is open to Afghan universities and selected US institutions of architecture, urban design and engineering programs for the Fall 2022. The competitors must register electronically between July 1st through September 30th on our website: www.afghanengineers.org

SAE Address: Society of Afghan Engineer
 P.O. Box 151584
 Alexandria, VA 22315, USA
 Email: Najim Azadzoï, AIA - azadarch@saol.com
 Prof. Bashir Kazimee, AIA - bkazimee@wsu.edu

SAE Society of Afghan Engineers

SAE Executive Report No. 28, March 6, 2023

AN UPDATE ON BAMIYAN HOUSING

FIRST PLACE WINNER OF THE AWARD

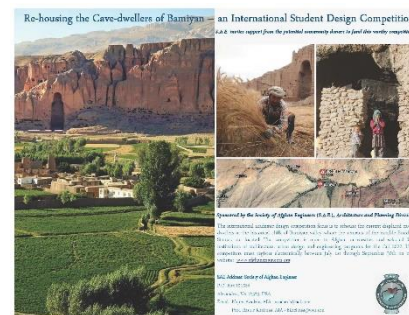

Congratulations to Ms. Kaiqing Tan, the first-place winner.

Ms. Kaiqing Tan of the Liverpool University, China is the first place winner of the Society of Afghan Engineers' International Students Design Competition, "Rehousing the Cave Dwellers of Bamiyan"
Cash Prize: \$2,500 plus a Certificate. Congratulations

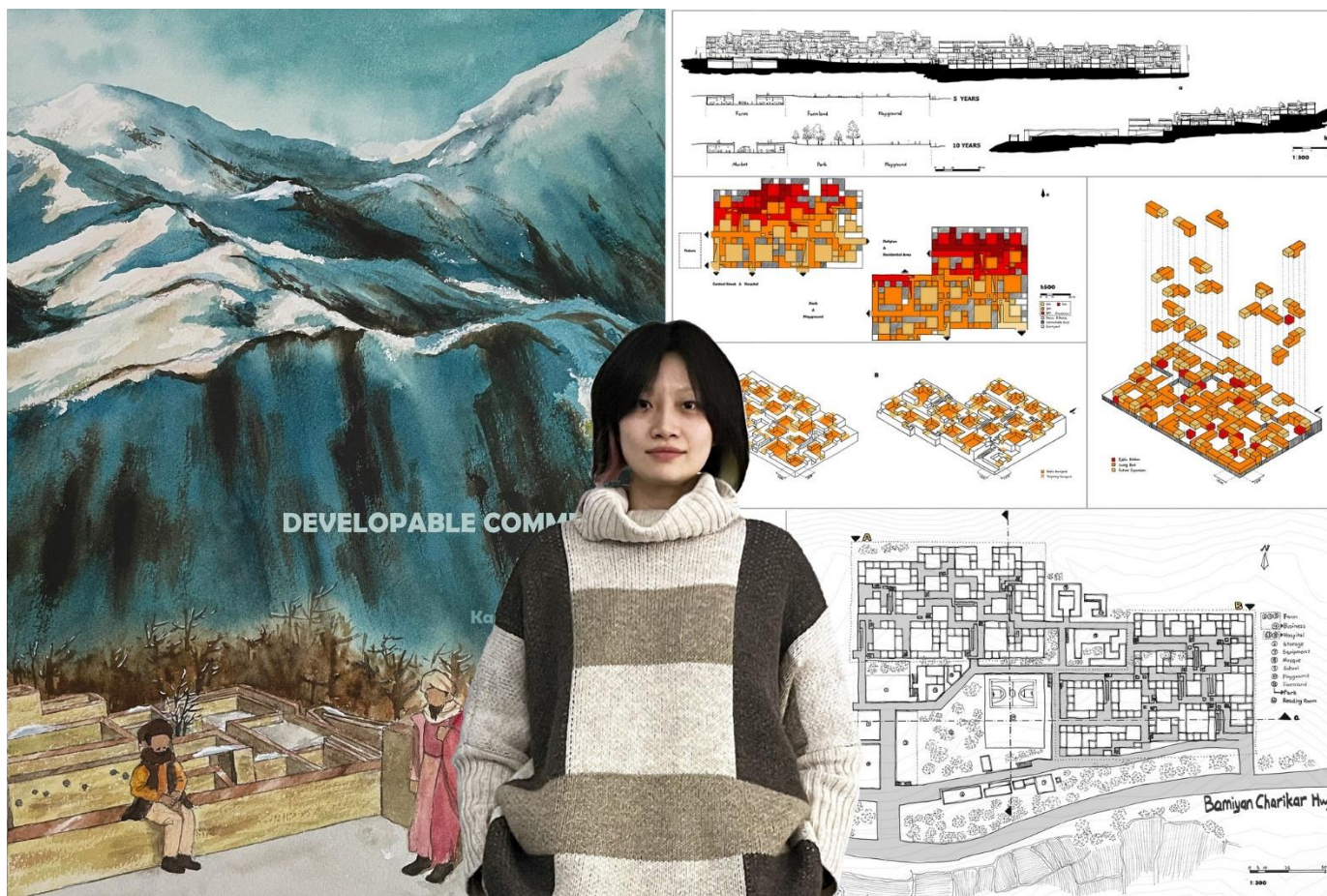

SECOND PLACE WINNER OF THE AWARD.

Congratulations to the second-place winner.

Architecture Students from Indonesia are thanking the Society of Afghan Engineers and celebrating their second-place winner of the Award.

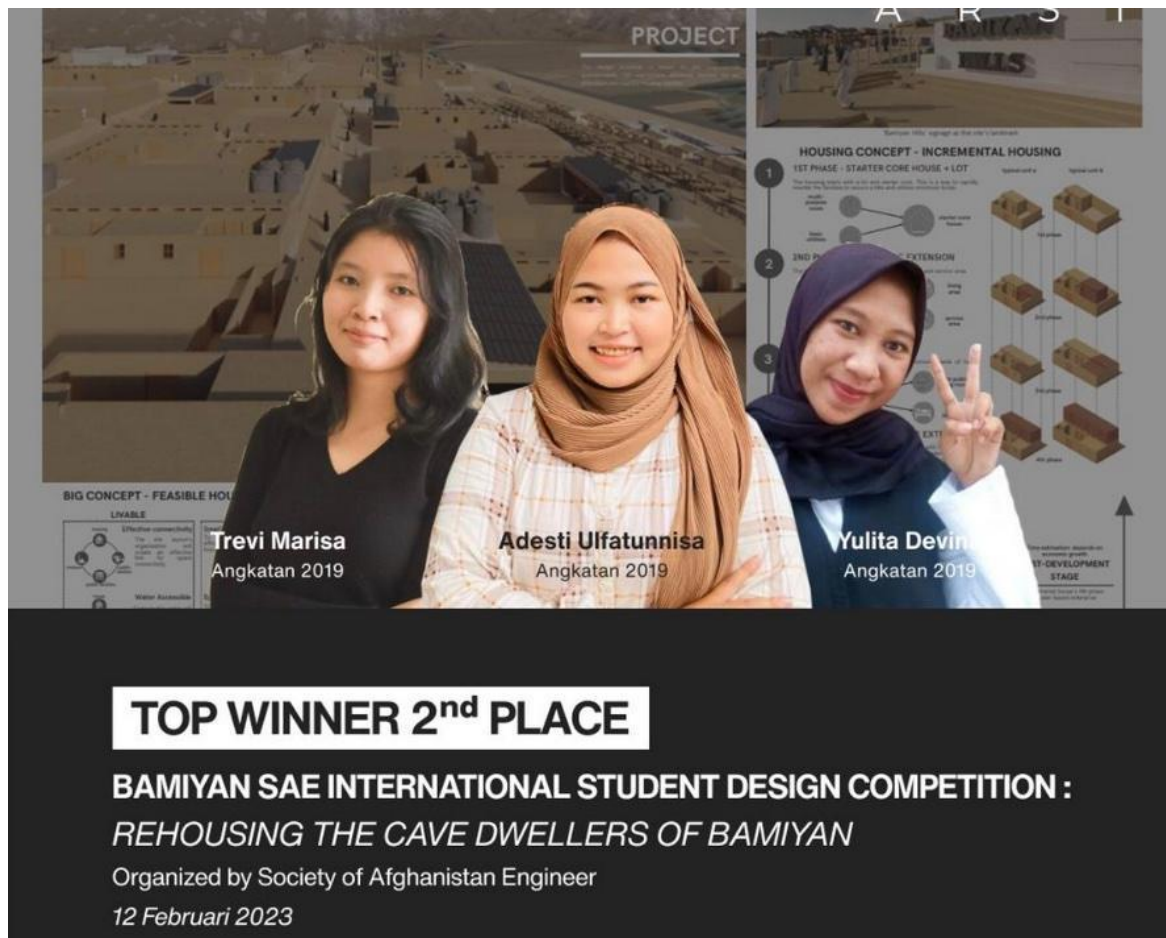

Najim Azadzoi, AIA. SAE President.



THIRD PLACE WINNER OF THE AWARD.

Congratulations to the third-place winner.

On behalf of The Society of Afghan Engineers (SAE) and the Subcommittee of Architecture and Urban Planning of the Society, I would like to congratulate Yuxing WU, Yang ZHANG, and Tianyi CHEN from the University of Nanjing Tech, Department of Architecture and Urban Design, College of Architecture in China for winning the 3rd place award of the Bamiyan International Student Competition 2023.



Twenty-three (23) entries from eleven universities around the world, including three universities from Afghanistan participated in this competition. Five internationally known Jurors completed the evaluation of the proposals from around the world and the winners were announced publicly.

Society of Afghan Engineers

Najim Azadzo, AIA, President

P.O. Box 151584

Alexandria, VA 22315, USA

www.afghanengineers.org

Tel: 617-558-4144, 617-697-7500

SAE Executive Action No. 29, February 7, 2023

ATIQ PANJSHIRI, CHAIRPERSON OF THE ELECTION COMMITTEE 2023

Nomination of Mr. Atiq Panjshiri for the position of **Chairperson of the SAE Election Committee, 2023**, was unanimously approved by the Board of Directors on February 4, 2023. The voting was cast through emails.

PROFILE of MR. ATIQ PANJSHIRI

ATIQ PANJSHIRI is Manager at Division of Land Development at Montgomery County Government, Maryland. He was Born and raised in Kabul, Afghanistan. Mr. Panjshiri has been living in the United States since 1981. He obtained his B.S. in Civil Engineering from the University of Maryland in 1988. Mr. Panjshiri is one of the founding members of the Society of Afghan Engineers and has served the Society as President (2014-2020), Vice President, Treasurer and Board member. He is the Founding President of the Afghan American Chamber of Commerce (AACC). He is the CEO and partner of United Insurance and Financial Services, Inc., which provides insurance, financial services, and corporate accounting services for clients in the Washington D.C. metropolitan area. In 1998, he co-founded the Afghan Sports Federation (ASF) and has served as Executive Vice President.



In 2002, he was instrumental in the establishment of the Afghan American Chamber of Commerce (AACC). In the same year, he was elected as the founding President of AACC and has served the organization as its Founding President and CEO from its inception until 2008.

Bachelor of Civil Engineering / 1988, University of Maryland, College Park, Maryland
College of Engineering / 1978 – 1980, Kabul – Afghanistan.

I congratulate Mr. Panjshiri and wish him a successful completion of the SAE election process in 2023.

Najim Azadzo, SAE President

Sincerely yours,
Najim Azadzo,
SAE President

SAE Executive Action No. 30, February 9, 2023

SAE ELECTION 2023

FORMATION OF THE SAE ELECTION COMMITTEE 2023

As per SAE Bylaws Section 6, election of the new SAE administration shall take place every three years. An Election Committee shall be formed during the year 2023 and shall be dissolved upon the completion of the election process.

The Election Committee consists of a Chairperson and four members. A Chairperson has been elected and Mr. Atiq Panjshiri will Chair the election Committee.

The four members are appointed by the Board of Directors through seeking nomination from Members.

Every Member of the Society has the right to recommend two Members to serve in the Election Committee. The Board of Directors will consider the recommendations received from the Membership with due references and will select four members.

Members of the Board of Directors and Executive Committee are not eligible for appointment to the Election Committee.

Members of the Election Committee will not be nominated as members of the Board of Directors and President. Also, they will not be nominated for the Executive positions of the Executive Committee.

Najim Azadzoi, SAE President



Design of Modern Digital Electronic Systems

Bahawodin Baha

University of Brighton, UK.

Abstract

Electronic systems have greatly affected the lives of nearly every individual across the globe over the last few decades, the widespread availability and use of cell phones and the internet are just few obvious examples. Despite incredible growth, the education of this important development has not been very strong in certain parts of the world. The objective of this paper is to highlight the recent development specifically programmable logic devices and their utilisation by the designers to develop modern electronic systems, especially Electronic Design for Automation (EDA) systems. Hence, recommendation will be made for the integration of such technology in engineering education of the less developing countries.

Key words: Digital Electronics, FPGA, ASIC, VHDL, Quartus

1. Introduction

Electronic devices and systems have experienced exponential growth over the last four decades, examples of such growth are the development of various generations of communication systems, computers and its networks, the Internet, and more recently smart electronic systems such as smartphones, self-driving cars, Internet of Things (IoT), Machine Learning (ML), robotics and Artificial Intelligence (AI).

Initially, vacuum tubes or valves were the main electronic devices which were utilized to design and build electronic systems. By the invention of transistors in 1947, valves were gradually replaced by semiconductor devices, i.e., diodes and different types of transistors. A further milestone in the semiconductor revolution was the integration of transistors in semiconductors Integrated Circuits (ICs) also known as chips.

Analogue electronic devices and systems were popular before the emergence of more dominant digital logic devices that gradually replaced most conventional analogue electronic systems, especially computers, communication, and other modern electronic systems.

In this brief article, digital devices and their applications are reviewed, and the recent developments has been discussed in more details.

2. Recent Development in Digital Technologies

Bi-Junction-Transistors (BJT) and Field-Effect-Transistors (FET) have been used to design and fabricate most digital logic devices. Therefore, two types of standard logic devices have been designed and fabricated

since 1970s [1]. These two types are called Transistor-Transistor-Logic (TTL) and Complementary Metal-Oxide-Semiconductor (CMOS) devices, which are shown in Figure-1. Traditional combinational and sequential logic devices, memory and microprocessors, microcontroller use either TTL or CMOS technologies. However, because of the recent improvement in semiconductor industry those digital devices which can provide just single function at much slower speed, other classes of digital devices including programmable devices such as Field Programmable Gate Array (FPGAs), Application Specific Integrated Circuits (ASIC) and full custom design were introduced as shown in Figure-1, these devices have many advantages including high speed, lower volume, low cost than using traditional TTL and CMOS digital devices.

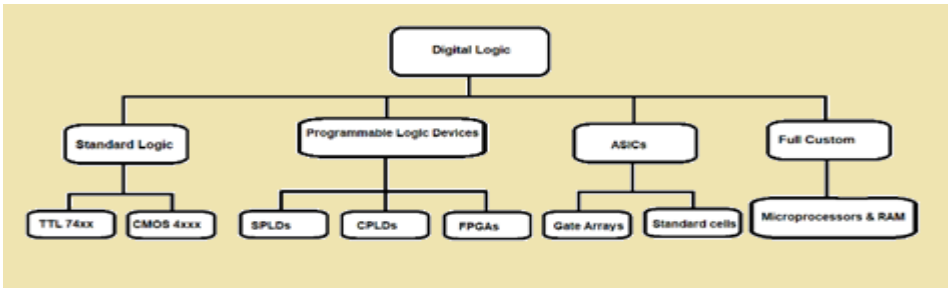

Figure 1: Different classes of digital devices and system design

Electronic design engineers encounter many challenges to design electronic devices and systems that will satisfy the present needs in the world so that the systems are faster, cost effective, lighter, smaller, smarter that can satisfy the customer requirements. One of the solutions to achieve these objectives is to utilise programmable devices such as FPGAs, which is briefly discussed in this document.

3. Field Programmable Gate Array (FPGA) Design

FPGA are general purpose programmable digital devices or ICs where most of the functionality inside the device can be changed and programmed by the designers and then integrated within electronic systems [1].

Many well-known semiconductor manufacturers have introduced their FPGA devices and related software platforms which will enable the designers to programme and integrate such devices in their electronic systems. Almost 90% of electronic system designers use the FPGAs from two of the world well known FPGA manufacturers, i.e., ALTERA now part of Intel and XILINX, part of Advanced Micro Devices (AMD). Some companies use Diamond FGPGA from Lattice semiconductors.

Electronic systems using FPGA spanning from communication systems to high-speed data centres, self-driving vehicles, aircraft navigation, smart energy grids, medical ultrasounds, robotics, drones, cloud applications and sophisticated high-speed computers– just to name a few.

Traditional computer control systems on single board were designed using Central Processing Unit (CPU), many input/Output (I/O) devices, Flash and static memory, Digital Signal processing (DSP) and FPGA on the same board as shown in Figure 2.

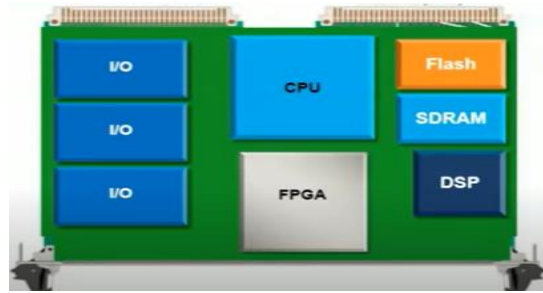

Figure 2: Traditional computer control system

However, because of the advances in semiconductor devices the designers can include CPU, I/O devices and DSP into a single FPGA device as shown in Figure 3.

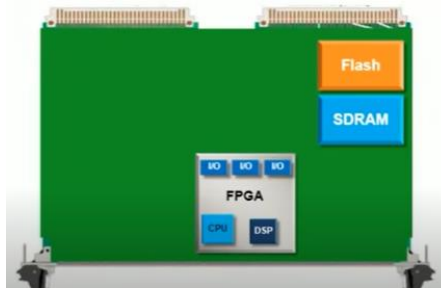

Figure 3: CPU and I/O units moved to FPGA

As a result of such integration in FPGA, the size and cost of the Printed Circuit Board (PCB) and power consumption of the PCB will be significantly reduced as shown in Figure 4.

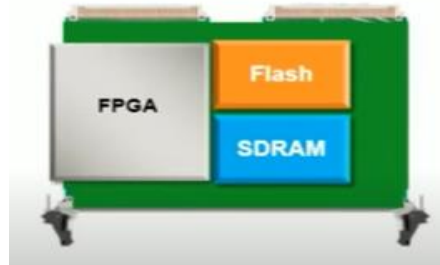

Figure 4: Smaller board size

The resources within the architecture of FPGA includes the following building blocks as shown in Figure 5:

- a. Logic Elements (LE), Look-up tables (LUTs) and registers
- b. Embedded memory
- c. Phase Locked loops (PLL)

- d. Hard processor System (HPS) usually Arm multi-core processor.
- e. User selectable I/O elements
- f. Embedded multiplier (DSP)
- g. Configuration registers and configurable routing

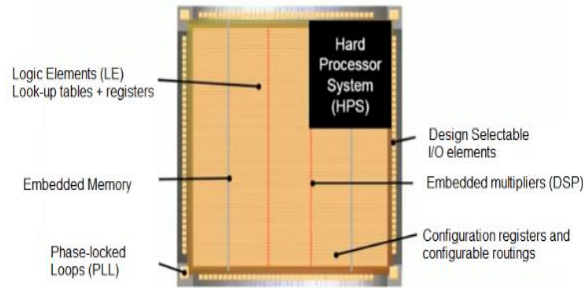

Figure 5: FPGA architecture

4. The Design process of FPGA

To design a digital system employing FPGAs, either Quartus platform from Intel [2] or Vivado platform from Xilinx AMD [3] can be used. Then the designer can choose either behavioral or structural design methods. Hardware Description Language (HDL) or Very High-Speed Integrated Circuit Description Language (VHDL) software language will be used in behavioral type of design while the circuit diagrams of the proposed digital system will be used in structural design. These steps of design include design entry, design synthesis, and design verification (including functional verification and timing verification and takes places at different points during the design flow), design implementation, and device programming. The design process for FPGAs presents a variation on these basic process as mentioned earlier in this paragraph.

VHDL or its companion language Verilog HDL are hardware description languages are used to describe digital logic circuit which is to be implemented in physical integrated circuits such as FPGAs and PLD devices.

Simple examples of both methods using the screen shots from Quartus are shown in Figures 6 and 7 respectively. Both Quartus and Vivado systems have reach library, where the designer can select various components from the library and modify and integrate those elements in their design. However, the design of a simple digital system has included in this paper.

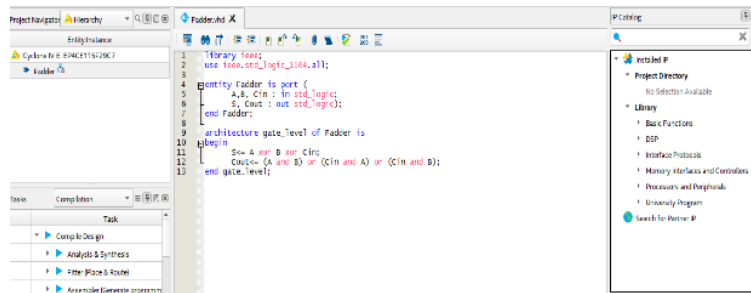

Figure 6: example of behavioral design method using VHDL code.

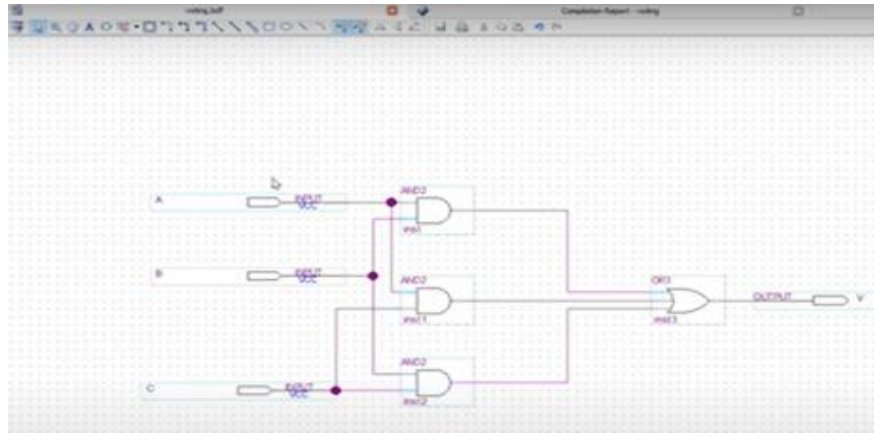

Figure 7: Example of structural design method using schematic of the digital circuit.

Once the system is designed in Quartus software using VHDL shown in Figure 6 or in the form of circuit diagram as shown in Figure 7, then Quartus software will be compiled and processed as shown in Figure 8.:

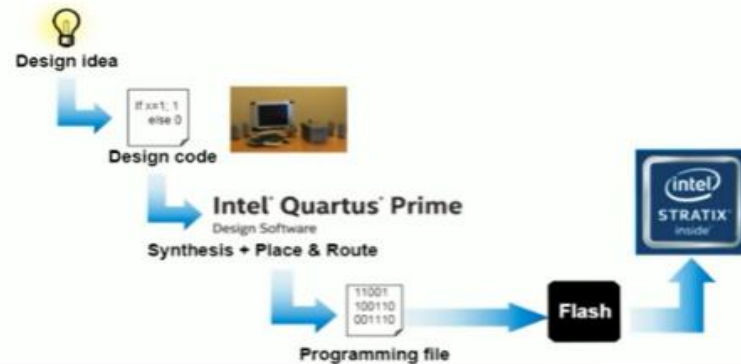

Figure 8: design process of FPGA

VHDL code or the circuit diagram created in Quartus or Vivado environments will be compiled and synthesized, then it will generate the equivalent binary code for the proposed system and then transferred to FPGA device via Flash memory as shown in Figure 8.

The developed code from VHDL or the circuit diagram will be synthesized and transferred to the relevant part of FPGA device as shown in Figure 9.

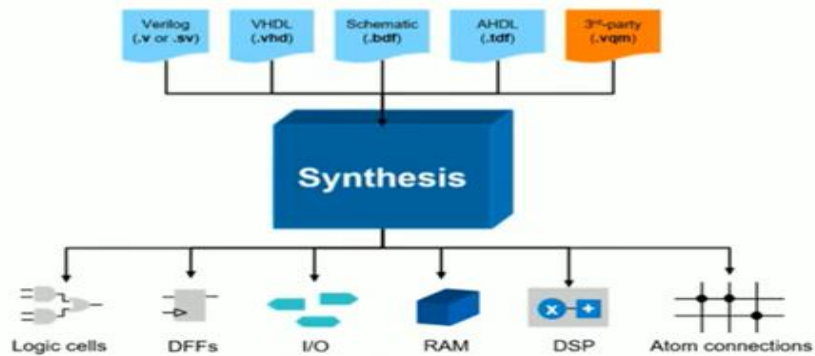

Figure 9: process of FPGA

The developed code will be tested with the aid of FPGA development boards shown in Figure 10 or 11. Alternatively, the development system can be verified with the help of input and output waveforms using Quartus or Vivado software as shown in Figure 12.



Figure 10: DE2-115 FPGA development system from Altera (INTEL)

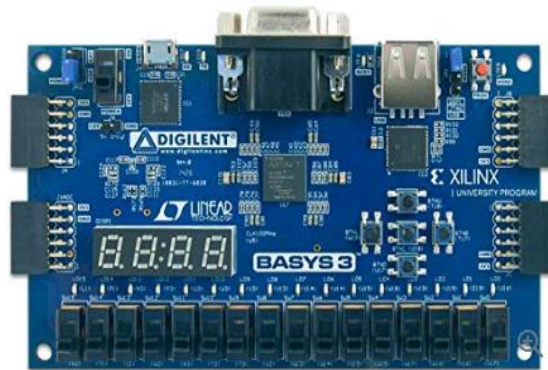

Figure 11: Digilent Basys-3 FPGA development system from XILINX (AMD)

Simple digital systems will be tested with the aid of switches and Light Emitting Diodes (LEDs) which are integrated in the boards shown in figure 10 and 11. Alternatively, the proposed can be analyzed with the aid waveforms shown in Figure 12, supplied by Quartus or Vivado.

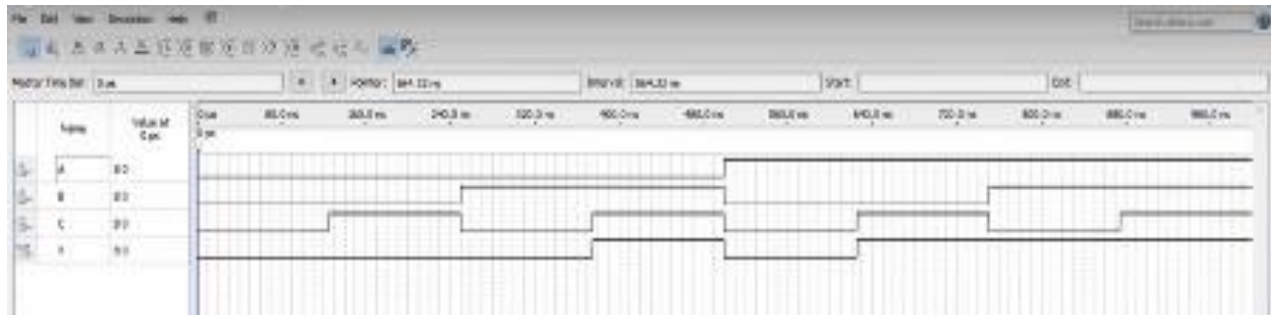

Figure 12: example of test results

The programmed FPGA devices will then be integrated in the new digital system, which will be working according to specification. An example of a digital system design using VHDL program has been successfully demonstrated in this paper and similar process can be used to design more complex digital systems. Both Quartus and Vivado platforms have rich libraries of already sub-systems which can be integrated by the designers in their own designs.

5. Conclusions

Traditional microcomputers and other digital systems were designed using TTL and CMOS devices in the past, the devices in such systems cannot be reprogrammed or modified in anyway. The results have been high number of electronic components on the Printed Circuit Board (PCB) which consumed more power and very uneconomical. Furthermore, a small error in the design of such electronic systems require new modification of the system hardware and the redesigning the PCB design which is lengthy and costly process. These problems can be rectified by the introduction of programmable devices where the system is designed by software and then the developed software is blown up in programmable devices such as FPGA. The programmed FPGA device is then integrated in the system which will be functioning according to the design specification. Any possible in the error in the design can easily be addressed by modifying the software and storing the modified software back in the FPGA device.

In this paper, the basic principles on designing modern electronic system utilising FPGA devices and a popular software platform Quartus from one of the world best semiconductor manufacturer, Intel has been demonstrated. Similar procedure can be applied to design electronic systems when using FPGA devices from other semiconductor manufacturers such as AMD.

Other advantages of applying FPGA in modern electronic systems are as follows:

- Flexibility and acceleration, software can be modified very quickly.
- Integration, many parts of the system can be integrated in FPGAs.
- The total cost of the system will be significantly reduced.

One of the important applications of such FPGA based systems is Electronic Design for Automation (EDA) which is used in self driving vehicles, IoT, 5G networks, satellite communications and consumer electronics.

Despite this amazing growth of electronic systems, the education of this important development has not been very strong in Afghanistan. Hence, it is strongly recommended that courses related to electronic engineering at universities in the country is revised and the new development in this subject are included in the new curriculum.

Surprisingly most of the software for FPGA based electronic systems is developed by professionals in countries such as India and then transferred to well-known companies in the US and Europe where EDA and other modern electronic systems are manufactured. Perhaps, the authorities in Afghanistan can learn from

such experience and educate the younger generations so that they develop capability to compete for jobs in the international markets.

References

1. Kleitz. W. Digital electronics with VHDL, Pearson Prentice Hall, New Jersey, Columbus, Ohio. 2013.
2. Intel® Quartus® Prime Lite Edition Design Software Version, 2020.
<https://www.intel.com/content/www/us/en/software-kit/660907/intel-quartus-prime-lite-edition-design-software-version-20-1-1-for-windows.html#:~:text=FPGA%20Platform%20Software-,Intel%C2%AE%20Quartus%C2%AE%20Prime%20Lite%20Edition%20Design%20Software%20Version,1%20for%20Windows&text=A%20newer%20version%20of%20this,includes%20functional%20and%20security%20updates.>
3. Vivado for students - for educational purpose, 2021.

[https://support.xilinx.com/s/question/0D52E00006hpaP5SAI/to-download-vivado-for-students-for-educational-purpose?language=en_US.](https://support.xilinx.com/s/question/0D52E00006hpaP5SAI/to-download-vivado-for-students-for-educational-purpose?language=en_US)

Biography of Dr Bahawodin Baha, (BSc - Afghanistan, MSc and PhD- UK)

Dr. Bahawodin Baha is a principal lecturer (associate professor) at University of Brighton in England since 1989 where he has been teaching and conducting research in electronic engineering. He published many papers on the analysis and design of electronic systems at international conferences and well-known international journals. His has recently been conducting research in Field Programmable Gate Arrays (FPGAs), Machine Learning, Artificial Intelligence (AI), Internet of Things (IoT), high frequency semiconductor devices and wireless communication systems.



Besides his teaching and research at University of Brighton, he was assisting Higher Education in Afghanistan from 2005 to 2021 through various projects on improving higher education in Afghanistan. He has trained some talented Afghan lecturers for Kabul Polytechnic University (KPU) at University of Brighton. He also took sabbatical leave for two years and worked as was a Technical Advisor at the Ministry of Communication and Information Technology (MICT) in Afghanistan. During his work, his activities were very closely associated with the Ministry of Higher Education (MoHE) and Kabul based universities. He has

published several papers about improving engineering education in Afghanistan at international conferences in Europe and north America. In addition, Dr. Baha has recently been promoting digital learning and remote teaching at universities in Afghanistan. He also developed a website (<https://www.afghan-higher-education.co.uk/>) in support of higher education in Afghanistan.

He was a visiting scholar at Virginia Polytechnic, Institute and State University (VPI), also known as Virginia Tech in the USA in 1991 – 1992 where he worked with talented electronic professionals who are working in Intel, Texas Instruments etc at present.

Kabul City Groundwater Aquifer Storage and Recovery

A Proposed Diversion Dam Across Logar River at Sang-i-Naweshta to Augment a Kabul City Aquifer Storage and Recovery (ASR) Program

(Part 4)

Amanullah Mommandi, M.S., P.E.



Figure 1. Site of proposed dam at Tang-I-Gharu

Abstract

This article is a continuation of a series of articles published in the SAE Newsletter (04/20; 04/22; 07/22; 01/23) proposing a Groundwater Aquifer Storage and Recovery (ASR) Program for Kabul City. In this article, the author proposes a new dam across Kabul River at Tang-i-Gharu to augment an ASR project. In addition, the proposed dam will retain sediments that cause damage to the Mahipar power plant and will create a new recreation area near the city.

Introduction

Over the last several decades, increasing water use coupled with decreasing recharge has resulted in the steep decline in the groundwater levels of Kabul city, triggering an ongoing water crisis. The drop in the groundwater table can be attributed to several factors including rapid population growth, excessive pumping of groundwater for commercial uses, and drought.

A promising strategy that can address the depletion of Kabul City groundwater is Aquifer Storage and Recovery (ASR), as detailed by the author in the April 2022 issue of the SAE eNewsletter. To briefly recap, ASR is the direct injection of surface water into an aquifer for later recovery and use. The injection and extraction of water are typically done through wells. In order to implement an ASR program, the construction of several dams across tributaries of the Kabul River around Kabul city is necessary to provide adequate water supply. The dams will provide a source of surface water to inject into depleted aquifers.

In this article (part of a series of articles about an ASR program for Kabul published in the SAE eNewsletter) the author proposes the construction of a new storage dam across the Kabul River at Tang-I-Gharu as one solution to support an Aquifer Storage and Recovery (ASR) for Kabul City that would address the municipal water needs of Kabul among other benefits.

The recommendation of a dam across the Kabul River at Tang-I-Gharu as a source for a Kabul city ASR project is time sensitive as Kabul is rapidly expanding both in terms of residential and commercial land use. These make the identification of a new water supply and the replenishment of already depleted groundwater aquifers a critical need.

A New Storage Dam on the Kabul River at Tang-I-Gharu

The proposed storage dam across Kabul River at Tang-I-Gharu will provide a source of water to be injected into depleted Kabul city aquifers. See figure 2 below for a schematic of the approximate location and a visualization of the resulting reservoir.

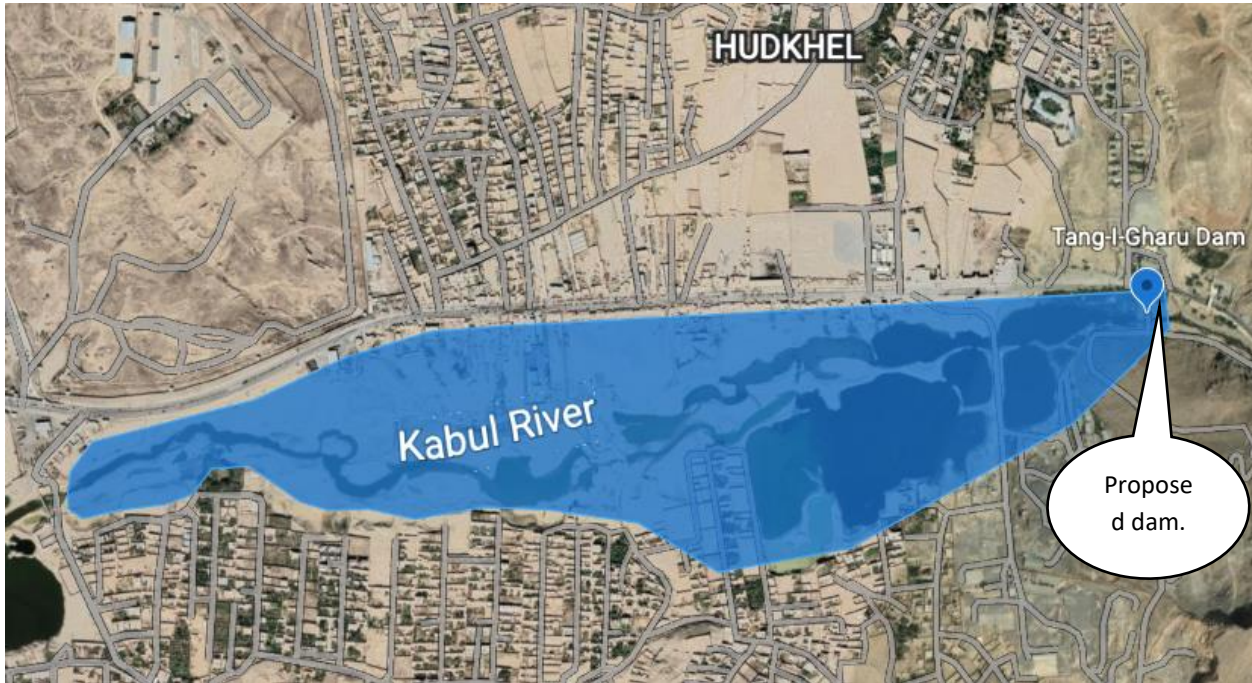

Figure 2. Location of proposed dam across Kabul River at the mouth of Tang-I-Gharu

For the construction of any dam over a river, several factors need to be considered including the geology and topography of a location. Importantly, long-term streamflow data is necessary to determine feasibility.

A stream gauge station (see Figure 3) installed by the Afghan Water and Soil Authority at Tang-I-Gharu in the 1960s has provided stream depth data since then which is used by engineers to calculate stream flow rates.



Figure 3. Stream Gauge Station at Tang-I-Gharu¹

Table 1 below summarizes the mean monthly streamflow rates at Tang-I-Gharu Station from 1962-1980 and 2006-2020. From January to June of each year, there is adequate stream flow for water to be stored by the proposed dam that can then be used to recharge Kabul city aquifers through an ASR program. If water is stored during high streamflow months, it can be diverted to extend the annual operating life of the Mahipar power plant.

Table 1. Tang-I-Gharu Station Monthly Mean Water Discharge, 1960-1980 & 2006-2020¹

<i>Month</i>	<i>Mean streamflow m³/s</i>	<i>Month</i>	<i>Mean streamflow m³/s</i>
January	16.47	July	2.00
February	17.73	August	1.24
March	26.11	September	0.86
April	43.80	October	2.32
May	23.20	November	8.57
June	5.04	December	13.94
Average Annual Runoff Volume			425.36 Mm³

Benefits and Advantages of a New Storage Dam at Tang-I-Gharu:

The primary benefit of the diversion dam will be to provide water for the Kabul City Aquifer Storage and Recovery Program (ASR). This program is a necessity considering the rapid growth of existing residential

¹ Source: Data courtesy of Aziz Rahman and Habib Rahmat, May -2021. Original data included mean monthly flow per month per year, we have consolidated date to provide monthly means over the entire time frame.

areas such as Pul-I-Charkhi and Ahmad Shah Baba Meena, and future planned residential and commercial growth to the northeast and southeast of the city. In addition to providing municipal water supplies for the aforementioned areas, the reservoir created behind the dam will be a source of recreation for families.

Figure 4 is from the Kabul Urban Design Framework. The map shows a development plan for the growth of Kabul over the next several decades. It shows future urban residential expansion plans to the northeast and southeast of the current city (see yellow shaded regions). These areas will lead to a significant increase in population and will increase the demand for municipal services. The location of the proposed dam at Tang-I-Gharu is strategically beneficial to the proposed expansion. It is close enough to provide the needed drinking water but also would be a large area of recreation for new residents.

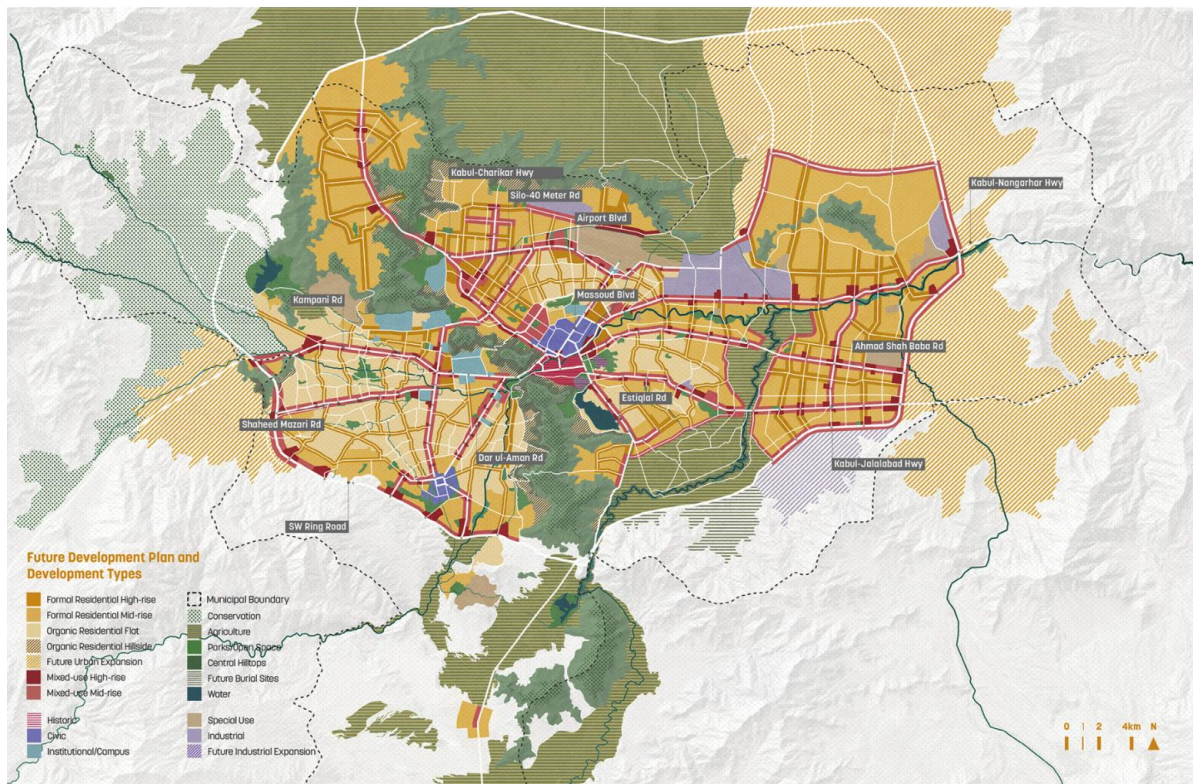

Figure 4. Kabul City Urban Design Framework²

² Source: <https://www.sasaki.com/projects/kabul-urban-design-framework/>

Additional benefits of the proposed dam include:

- Extending the operational life of the nearby Mahipar Hydroelectric Power plant by:
 - Retaining abrasive bedload sediments resulting in clearer water being sent that will not damage plant turbine blades.
 - Allowing the plant to operate for more months every year through the use of stored water in the reservoir, resulting in increased hydroelectric output.
- The retention of the sediment by the proposed dam will also extend the useful life of Naghlu reservoir, located downstream.
- Increase local sand mining potential.

Precautions and Disadvantages of a New Storage Dam at Tang-I-Gharu:

- The water surface elevation of the new reservoir must be at least two meters lower than the main Kabul city drainage outfall to the Kabul River. The reservoir must not cause backup flow into the drainage channels outfalls.
- Existing residents and businesses located near the proposed dam site and in the floodplain of the proposed reservoir will have to be displaced.

Conclusion

Prior to embarking on the construction of this dam, a full feasibility study is required to identify additional pros and cons of the project.

The recommendation to build a dam at Tang-I-Gharu is time sensitive as Kabul is rapidly expanding both in terms of residential and commercial land use. The identification of a new water supply and the replenishment of already depleted groundwater aquifers is a critical need.

Amanullah Mommandi, M.S., P.E.

Email: mommandia@gmail.com

Phone: (303) 217-6803

Life of The Late Professor Abdullah Breshna

By

Dr. Said Sharif Hossainy



Abdullah Breshna, from 1933 to 2021

Abdullah Breshna, was born in a famous artistic family in Kabul City, Afghanistan on January 7, 1933. He graduated as a top student from Amani (Nejat) High School . After graduation from Nijat High School, he received Government Scholarship to pursue his Architectural Engineering degree abroad. He received his Eng. Arch. Diploma from Karlsruhe University in Germany. After his graduation from Karlsruhe University, he served as Professor Egon Eiermann's assistant at the same university until 1961. He also worked in the private sector, including the office of Professor Egon Eiermann, on a number of projects, such as the Kaiser Wilhelm Memorial Building in Berlin and the German Embassy in Washington, DC, USA.

Mr. Breshna returned to Kabul in 1961 and began his professional career at the Ministry of Public Works. After performing his one-year military service in 1963 he worked with the Ministry of Public Works as the president of urban planning, from 1964 to 1972. During his services with Ministry of Public Works he also taught as Professor in the newly established Department of Architecture of the Faculty of Engineering of Kabul University from 1964 -1966. In 1966, for the first time, renovation of Dar-ul-aman Palace started. Architect Breshna became in charge of the renovation, He was also in charge of the restoration of a few other historical monuments in Afghanistan, including, Chehelsotun Palace, Bagh-e-Bala Palace and the National Archives of Amir Abdul Rahman Military School.

From 1965 to 1972, he participated in a few international conferences and seminars that were held in New York, Washington, Nagoya, Tokyo, Osaka, Delhi, Moscow, Samarkand, Berlin (Germany) and Tehran.

In 1966, the General Directorate of Urban Development and Housing was established under the Ministry of Public Works at the initiative of architect Breshna which worked extensively with the United Nations Development Program (UNDP) on the development of urban planning in Afghanistan. The program lasted until 1974.

Architect Breshna is the founder and a pioneer of the modern architectural style in Afghanistan. Breshna emphasized that the climate of Afghanistan should always be considered in the design. Indeed, he introduced modern urban planning in Afghanistan. Architect Breshna included all of Afghanistan's provinces in modern urban planning, especially in areas with a population of over 20,000, and fully supervised and managed the projects. Author had the honor of accompanying him to survey the Kajah New Town project in Khogyani District, Nangarhar Province in the spring of 1964. In Kabul, the development of Wazir Akbar Khan, Khair Khaneh Mina, and Seyed Noor Mohammad Shah Mina were under the supervision Professor Breshna and such process was followed in various other districts of Kabul.

Mr. Breshna and Engineer Nasir Saberi were the founders of the first non-governmental architectural and engineering company called ABAD in Kabul. ABAD was active from 1966 to 1979 and designed several government buildings and mosques; commercial buildings, including Majnoon Shah Mosque in front of the Ministry of Foreign Affairs, Ministry of Planning, Park hotel in front of Kabul Municipality and more than 100 beautiful and modern residential houses in Wazir Akbar Khan and other parts of Afghanistan. There were designed with excellent, engineering and architectural standards. It should be noted that at ABAD, young architects and engineers under the leadership of architect Breshna and engineer Saberi received practical and professional training.

From 1972 to 1978, he served as Chairman of Afghan Construction Unit of Kabul "ACUK" and was in charge of managing and developing the high rise building of Pamir Cinema. He changed the facade of the building pleasantly and beautifully. Also, at the direction of late President Mohammad Daud, Breshna presented the proposed plan for the Ministry of Communications building for the first time.

Architect Breshna is one of the founders of the Central Authority for buildings and Town Planning – (SHTAPA – De Shari au Tamirati Prodjo Anstitut), it was established in 1979, within the framework of the Ministry of Public Works. (Author: At that time, I was working in "SHTAPA" as the General Manager of the Architectural Department.)

In 1980, he and his family reluctantly left his beloved country for obvious reasons, and settled in Germany as refugees. He was a guest professor in German Universities for more than 15 years. He taught in a few German universities; including Stuttgart, Karlsruhe and Kassel Universities with a special focus on architecture for Third World Countries, promoting traditional clay architecture, informal areas, like (Om Dorman) in the city of Khartoum in Sudan, and the preservation and revitalization of the historic city of Zanzibar and the old city of Cairo in Egypt. As a talented architect with the German Bauer-Plan (Ludwigshafen /, Bauer-Plan), he was involved in many construction projects.

In 2002, at the request of the Afghan Government, he returned to his beloved homeland and participated in the Society Afghan Engineers (SAE) International Conference on Afghanistan Reconstruction. There onwards, he served as a Senior Consultant on many engineering projects and worked in urban planning in Afghanistan. He performed the first design of the new city of Kabul, and proposed the settlement of about 2,000,000 people in Kabul's Dehsabz district.

In 2005, Professor Breshna presented a proposal for the reconstruction of the old parliament building, as well as its new office building, which was located next to the Ministry of Commerce.

Since the author of this analytical biography research, has worked closely with Professor Breshna, he consider him to be a patriot, a lover of dear Afghanistan, kind and talkative. Breshna was very proficient in hand drating, and his sketches were so precise that they could be applied directly in the field. He was also proficient of Dari language calligraphy.

Due to close collaboration, the author considers Profesora Breshna as a patriot with deep love for his country and people.

Profesor Breshna is son of a famous master and artist, with a multidimensional personality; painter, poet, playwright, prominent musician and composer, Abdul Ghafoor Breshna and Mrs. Margaret Breshna.

Architect Abdullah Breshna married Shima Karim; and was blessed with four children, named, Dr. Zahra Twonplaner, Dipl. Engineer, Abdul Habib, Dipl. engineer Mohammad Yousef and Mohammad Daud (he passed away before his father's death) and five grandchildren named Elias, Arian, Navid, Zalmai and Maryam.

On August 14, 2021, Professor Breshna joined the mercy of God in the city of Karlsruhe, Germany, and was buried in the Muslim cemetery in Karlsruhe, next to the tomb of his late son Mohammad Daud.

MEMBERSHIP NEWS

SAE is pleased to announce that many professional engineers and architects in the United States, Canada and Afghanistan have shown their interests becoming SAE team members since January 2021. SAE has received most of new members' membership applications and fees as required by the SAE bylaw. We welcome everybody and looking forward working together in future projects by providing professional services to Afghan Government and agencies. We publish new members' names and their short biography in each SAE quarterly eNewsletter as provided the information.

We welcome our newest high qualify members and look forward to their contribution to the purpose and mission of the Society of Afghan Engineers as set forth in the bylaw of the society.

SAE Society of Afghan Engineers

SAE New Members April, 2023

Brief biography of: HASHMATULLAH ATMAR

Hashmatullah Atmar son of Shamsulhaq Atmar, born on 24 May 1963 in Bulan village, Qarghae Distract of Laghman province, Afghanistan.

He completed his Primary and high school studies at Aqa Ali Shams School and Habibia high School in Kabul,

Mr. Atmar studied bachelor and Master degree at architecture faculty of Azerbaijan Civil Engineering Institute (Azerbaijan University of Architecture and Construction) from 1982 to 1988 and he also persuade his studies in Architecture field and gained PHD degree from the same university from 2005 to 2007.

Started work with PAMA (Central Planning Project Institute) as a head of education and health department, and lecturer of Engineering Faculty at Kabul University (part time) for 10 years.

From 2001 started work with Zone of Maximum Design (ZMD) Turkish design and Construction Company as a project manager in Kabul.

He continued his tenue as technical Manager with Technology Innovation Manufacturing (TIM International) Turkish based prefab company in Kabul till 2017.



Mr. Atmar is currently working as Controller of architectural projects for Directorate of Design of Construction Affairs as well as lecturer of engineering faculty at Salam University.

Alongside to his working tenure he designed more than 800 architectural details, small, middle, large, complexes and shop drawings for Afghanistan, out of country in this period.

Furthermore he is author of 38 volume books, in which 28 of these volume books are about architecture (especially Afghan architecture), the remaining 8 are architecture with Islam religion and the last 2 are navels in Pashto and Dari languages.

Contact number: +93799376998

Email address:atmar_hashmatullah@yahoo.com

Eng. Abdul Bari Momand

Email Address: abdulbarimohmand786@gmail.com



Education

2014 Graduated from Shaikh Zayed University Civil Engineering Department

Khost Afghanistan.

Work Experience

MINISTRY OF URBAN DEVELOPMENT AND LAND (MUDL)

From 22/August/2017 up to 22/August/2022.

Position: Land Technical Engineer (cadaster)/ Logar province Urban Development and Land directorate.

ABID RAHIMI CONSTRUCTION COMPANY (ARCC)

From 01-Sep-2015 up to June-2017.

Position: Site Engineer /Logar province Pole-e-Alam District.

HELVETAS SWISS INTERCOOPERATION

From 15-May-2015 up to 15-Aug-2015.

Position: Field supervisor / Bamyán province Sighan District.

Site responsibility of implementation of irrigation projects.

ONYX CONSTRUCTION COMPANY

From Aug-2014 to 16-Oct-2014.

Position: Intern / Kabul province Khwaja Rawash.

SAE Membership Payments

Society of Afghan Engineers (SAE) Membership Fees-2023 (USD)

Active Members

No	Last Name	First Name	2021			2022			2023		
			Fee	Donation	Total	Fee	Donation	Total	Fee	Donation	Total
1	Abdulrahimzai	Mushtaq				60	0	60			0
2	Afshar	Reza M.	60	40	100	60	90	150			0
3	Ahmady	Ahmad Jawid				60	0	60			0
4	Amiri	Donya				60	40	100	60	40	100
5	Atayee	Tamim	60	0	60	60	40	100	60	38	98
6	Azadzoi	Najim	60	140	200	60	140	200	60	40	100
7	Babacarkhial	Abdul Nazeer	60	0	60	60	70	130	60	0	60
45	Baha	Abraham	60	60	120			0	60	60	120
8	Baha	Zarjan	120	0	120	60	60	120			0
9	Baidariwal	Fazal	0	60	60	60		60	60	0	60
10	Baluch	Hashem	60	0	60	60	0	60	60	0	60
11	Corcoran	Edward	60	0	60	60	92.75	152.75	60		60
12	Durani	Ahmad Shah				57.31	0	57.31			0
13	Farooqi	Najibullah	60	140	200	60	100	160	60	100	160
14	Feda	Ghulam							60	40	100
14	Hassani	Abdul Waheed	60	0	60	60	0	60	60	40	100
15	Hossainy	Said Sharif	60	40	100	60	40	100	60	60	120
16	Ibrahim	M. Hamayon	60	0	60	60	0	60	60	38	98
17	Kazimee	Bashir	60	40	100	60	40	100			0
18	Keshawarz	Saleh	60	0	60	60	0	60	120		120
19	Khalid	Manan	60	40	100	60	0	60	60	40	100
20	Ludin	Rafat	60	90	150	60	74	134	60	0	60
21	Mahmood	Amin	60	40	100	60	150	210	60	40	100
22	Masumi	Jalal	60	40	100	60	130	190	60	0	60
23	Mommandi	Amanullah	60	0	60	60	40	100	60	40	100
24	Mujtaba	Ghulam	60	140	200	60	140	200	120	80	200
25	Mujtaba	Bahaudin	60	40	100	60	40	100			0
26	Omarzad	Mustafa	60	0	60	40	0	40			0
27	Panjshiri	Atiq	60	0	60	60	0	60	60		60
28	Rakin	Hadi	60	0	60	60	0	60	240		240
29	Roshan	Tooba	60	0	60	60	440	500			0
30	Rossi	Steve	60	200	260	60	440	500	60	200	260
31	Sabet	Mehdi	60	0	60	60	0	60			0
32	Saleh	Gul Afghan	60	40	100	60	40	100	120		120
33	Samizay	Mahmoud	60	40	100	60	40	100			0
34	Samizay	Rafi	0	0	0	60	0	60	60		60
35	Sarfraz	Zabiullah	0	0	0	60	0	60			0
36	Sidiqi	Nadir	60	0	60	60	0	60	60	60	120
37	Wais	Aria				60	40	100			0
38	Wardak	Hafizullah	60	0	60	60	0	60	60	0	60
39	Wardak Hassan	Wazma	60	0	60	60	0	60			0
40	Yamayee	Zia	60	200	260	60	200	260	60	300	360
41	Zaca	Zabiullah	60	40	100	60	40	100			0
42	Abdul Qayum	Abdul Rauf	60	0	60			0			0
43	Abdullah	Ehsan	60	0	60			0			0

44	Afghan	Fazel Ahmad	60	0	60			0			0
46	Ebadi	Yar M.	60	40	100			0			0
47	Ghani	Aziz	60	140	200			0			0
48	Taraky	Yar Mohammad	60	40	100			0			0
49	Mehrzaei	Jan	60	0	60			0			0
50	Miller	Hamida	60	0	60			0			0
51	Naimi	Qaseem	60	40	100			0			0
52	Noorzad	Abdullah	60	0	60			0			0
53	Paya	Najib M.	60	200	260			0			0
54	Shekib	Sohaila	60	0	60			0			0
55	Hassan	Islamudin	0	0	0			0			0
56	Qadir	Abdullah	0	0	0			0			0
57	Rayek	Hashim	0	0	0			0			0
58	Sattari	Masood	0	0	0			0			0
59	Shirzay	Ahmad Wali	0	0	0			0			0
60	Zahori	Sayed	0	0	0			0			0
61	Goethert	Reinhard							60		60
62	Levrat	Fred									

					\$4,710				\$4,964		\$3,316
--	--	--	--	--	---------	--	--	--	---------	--	---------

SAE Members In Afghanistan (exempt from membership payment)

1	Zhakfar	Zabihullah									
2	Kamran	Matiullah									
3	Momand	Mohammad Ishaq									
4	Momand	Mohammad Fazil									
5	Zahid	Hasibullah									
6	Saberi	Safi									
7	Asim	Arif									
8	Naimi	Kazim									
9	Hmadard	Sahar									
10	Howaida	Ahmad Walid									
11	Maihan	Regina									
12	Alizoi	Mohammad Azim									
13	Hussaini	Muzhda Sahadat									
14	Sattari	Mashhood									
15	Qadery	Qadria Shewa									
16	Nazarian	Tayebah									
17	Ezzat	Abdul Mobin									

[Members Can Send Their Fees and Donations To The Following Account](#)

SAE Bank Account Information:

Account Name: **Society of Afghan Engineers**
Bank Name: **BB&T**
Routing # **051404260**
Account # **0005139262982**

Bank Address:
7915 HENESKA LOOP
ALEXANDRIA, VA 22315-0000 USA

SAE New Mailing Address

The SAE president, Najim Azadzoj, and the Afghan Academy President Mr. Hassan Shirdle, met in Virginia on January 7, 2021, to discuss the possibility of future activities between the two non-profit organizations. As part of mutual relationships, the Afghan Academy provides an office for SAE and sharing the mail address.

As of June 1, 2021, the Society of Afghan Engineers will have a new physical address. The new SAE address is:

**The Society of Afghan Engineers
P.O. Box 151584, Alexandria, VA 22315, USA.**

Engineering Job opportunities With Planate

The following positions are available at Planate Management Group

Planate Management Group (PMG) is a Service-Disabled Veteran-Owned Small Business (SDVOSB) headquartered in Alexandria, Virginia, and Orlando, Florida USA with a technical support centers in South East Asia and East Africa, that provides program management and facilities engineering services worldwide. Planate is a small business provider of planning, design, infrastructure management, technical consulting, engineering, and construction management services in support of the US Department of Defense (DOD) and its Service (Army, Air Force, Navy, Marine Corps) missions, along with other US federal agencies, all over the world.

[Senior Project Engineer \(Remote within USA\)](#)

[Medical Equipment Planner \(Palo Alto, CA\)](#)

[Structural Design Manager \(Palo Alto, CA\)](#)

[Senior Interior Designer \(Palo Alto, CA\)](#)

[Electrical Engineer \(Palo Alto, CA\)](#)

[Mechanical Engineer \(Palo Alto, CA\)](#)

[Liaison Officer \(Koror, Palau\)](#)

[Engineering Technician \(Camp Lemonnier, Djibouti\)](#)

[Finance and Accounting Manager \(Remote within USA\)](#)

Please visit our career site <https://planate.com/careers/> to view other job requirements.

For inquiries, you may email recruitment@planate.com.

***COVID 19 PROTOCOL:** Due to the nature of work, the successful candidate will be required to comply with all Federal guidelines regarding vaccination for all employees and contractors (as applicable in the respective U.S. State or outlying area). Please refer to **Executive Order 14042, Ensuring Adequate COVID Safety Protocols for Federal Contractors** for more information.*

Why Planate?

Planate Management Group is an Affirmative Action and Equal Opportunity Employer. All qualified applicants will receive consideration for employment without regard to race, color, religion, sex, sexual orientation, gender identity, national origin, or protected veteran status and will not be discriminated against on the basis of disability.

Joining the Planate team opens you to an experience working for a Global company where you are among a team that is considered a premier trusted partner for planning, design, engineering, asset management, and professional service solutions anytime, anywhere. We Take Care of Our Own; Personally, and Professionally, Up and Down The Line.

We'd love for you to be a part of our Global workforce, helping us serve as an effective and integrated partner to advance every client's mission!

Please do not hesitate to reach out for clarifications or questions.

Thank you!

Very Respectfully,

Mapet D. Santos, CRSP

Senior Technical Recruitment Officer

Planate Management Group, LLC

1800 Diagonal Road, Suite 600

Alexandria, VA 22314

Tel: +1 (407) 674-5454

www.planate.com

A Service-Disabled Veteran-Owned Small Business (SDVOSB)

This message may contain business confidential, pre-decisional, proprietary or sensitive but unclassified information and is intended only for the individual named; do not further disseminate or forward, this email (electronically or physically) without the express written consent of the sender. If you are not the named addressee you should not disseminate, distribute or copy this e-mail. Please notify the sender immediately by e-mail if you have received this e-mail by mistake and delete this e-mail from your system.

Very Respectfully,

Mapet D. Santos, CRSP

Senior Technical Recruitment Officer

Planate Management Group, LLC

1800 Diagonal Road, Suite 600

Alexandria, VA 22314

Tel: +1 (407) 674-5454

www.planate.com



A Service-Disabled Veteran-Owned Small Business (SDVOSB)

This message may contain business confidential, pre-decisional, proprietary or sensitive but unclassified information and is intended only for the individual named; do not further disseminate or forward, this email (electronically or physically) without the express written consent of the sender. If you are not the named addressee you should not disseminate, distribute or copy this e-mail. Please notify the sender immediately by e-mail if you have received this e-mail by mistake and delete this e-mail from your system.

COMMENTS AND SUGGESTIONS

The Editorial Board of the SAE eNewsletter welcomes comments and suggestions from the respected Society members and readers of the Newsletter. Your comments and responses will be included for information of all readers of the SAE eNewsletter.

Comments Received on Januaryr 2023 issue of SAE:

Comments on the January 2023 Issue.

Kazimee, Bashir A

Sun, Jan 1, 11:46 AM
(2 days ago)

to Najim, rgoethert@aol.com, Mehdi, Rafi, donya@aimeci.com, me

Dear Wardk Saahib:

Thank you for your wonderful note and the SAE-Newsletter, I admire your hard work and the time you put on this issue.

However, I noticed my article "an update on the Bamiyan competition," is not fully published. I see an important section about our Jurors, their biography and photos are totally missing. As you know this is an important piece of information that we were going to publicize and forward it to those involved in the competition.

I am not sure how it can be rectified?

Please advise!

Regards,

Bashir Kazimee, AIA
Professor Emeritus, Washington State University
Chairperson SAE Architecture/Urban Design Division

Hafiz Wardak <hafizwardak@gmail.com>

Sun, Jan 1, 12:46 PM
(2 days ago)

to Bashir

Kazimee Sahib Salam

Page | 46

I apologize that some part of your update is missing. I included what you sent, could you please resend me the complete one. I will resend to those who really matter or are part of this project, add and resend the newsletter
Regards

With warm regards
Hafizullah Wardak
Editor-in-Chief of the SAE eNewsletter

Sharif Hossainy

Mon, Jan 2, 4:08 PM
(16 hours ago)

to me

Dear Ustad Mohtaram Eng., Hafizullah Wardak Editor-In-Chief SAE eNewsletter and Chairman of the Editorial subcommittee. Asallam-o- Alaikom,

I acknowledge receiving your email, regarding the first quarterly issue of the 2023 SAE eNewsletter. I wish you and your respected family a happy, and safe new year 2023.

Thanks for publishing my article. Thank you and Editorial subcommittee, Ustad Mohtaram Eng. Manan Khalid's and Ustad Mohtaram Dr. Hassani's. for kind efforts and volunteering.

As you mentioned, Afghans are facing many problems. For the uncomfortable events in 2022, about the education and work of the women and ladies of our dear country, Afghanistan I am regretful and they are unacceptable to me, but I pray to God (SWT) and I will never be disappointed, I hope this Contradiction will be resolved with continuous struggle.

Best Regards

Dr. Said Sharif HOSSAINY
E-mail: sharifhossainy@hotmail.com
Tel: + 604 477 1232
iPhone + (778) 840 8280 (WhatsApp)

Hafiz Wardak <hafizwardak@gmail.com>

Mon, Jan 2, 5:26 PM
(15 hours ago)

to Manan, Abdul, Najim, Sharif

Mohtarem Hossainy Sahib ,
On behalf of the Editorial Board, I would like to thank you for your comments. We appreciate comments from the readers of SAE eNewsletter.

With regards

Hafizullah Wardak
Editor-in-Chief of the SAE eNewsletter

On Mon, Jan 2, 2023 at 9:03 PM Habib Rahmat <habib.rahmat@gmail.com> wrote:

Dear Wardak sahib

Thanks for the News letter of 2023. I and rest of Afghanistan's people agree with you ,but main issue is that "How to change or help to change this very bad situation in the country " should be shared with Afghan and USA intellectuals in your publication.

Regards

Hsbib Rahmat Mayar

From: **Hafiz Wardak** <hafizwardak@gmail.com>

Date: Tue, Jan 3, 2023 at 8:49 AM

Subject: Re: SAE January 2023 eNewsletter

To: Habib Rahmat <habib.rahmat@gmail.com>

Cc: Manan, Abdul, Najim

Dear Rahmat Sahib,

On behalf of the SAE eNewsletter Editorial Board thank you for your warm comments. Your comments are appreciated. Your input and support to SAE are always recognized and welcomed. Please continue to support us with some of the latest technology news and articles. Recently there has been interesting news about the Qushtipa Canal north of the Amu River if you know and can write an article about that, it can be considered for the next issue of the newsletter.

With warm regards

Hafizullah Wardak

Editor-in-Chief of the SAE eNewsletter

Nadir Sidiqi

Jan 2, 2023,
7:08 PM

Muhtaram Eng. Sahib Wardak, Assalam Alyaikum, Happy New Year to you and your respected family

Every time I receive the SAE e-Newsletter, it carries a wealth of knowledge and experiences, and I am enjoying reading it. Thank you very much for all the hard work to you as well as to other SAE respected colleagues.

We ask Almighty Allah to grant Taliban guidance to open the door of schools and universities in our beloved Afghanistan through education to turn the country into prosperity. Ameen

Page | 48

Best regards,
Nadir Sidiqi

Dr. Nadir Sidiqi Ph.D.
President/Dean of Academic
BioNatural Healing College

Response of the Editorial

Hafiz Wardak

8:27 AM (1
minute ago)

to Manan, Abdul, Najim, nadir

Mohtarem Doctor Sahib Sidiqi Walaikum Salam,

On behalf of SAE Editorial Committee, thank you for your comments. Glad to know that you received the January issue of the SAE eNewsletter. Your comments are appreciated, it is encouraging to know that you read and like the content of it.

With warm regards
Hafizullah Wardak
Editor-in-Chief of the SAE eNewsletter

THE 2023 SAE MEMBERSHIP RENEWAL

Dear Members of the Society:

The Management of the Society of Afghan Engineers (SAE) would like to remind all members that 2023 membership renewal and Annual fee of \$60 are due. Your membership fee collectively would enable us to pay for some basic needed services of the Society such as Website security monitoring, updating, and maintenance. Also, your membership fee would provide SAE's management, the financial means to organize and host events and seminars on relevant technical topics. The membership renewal application is attached to the Newsletter and also can be downloaded from our website at www.afghanengineers.org

Please visit the SAE Face book when you get the opportunity. We appreciate your kind attention to the membership due request.

Sincerely,

Najim M. Azadzoi, AIA, President

The Society of Afghan Engineers

SAE eNewsletter Regional Representatives

The positions of the SAE eNewsletter Regional Representatives are open. Please let us know if you are interested to volunteer for one of these positions or if you want to nominate other qualified members to serve in these positions. The representatives will inform the newsletter Editorial Board of any technical news in their regions and contact authors for their contributions in the activities of newsletter. For additional information please send an email to SAE eNewsletter Editorial Board: Hafizullah Wardak, E-Mail: hwardak@comcast.net; A. Wahed Hassani, Email: awhassani@gmail.com; and A. Manan Khalid, E-Mail: manank10@gmail.com;

The attached form includes application for the new members and membership renewal.

The application forms may be viewed at SAE website. The members are requested to take a few minutes of their time to inform the Society by sending their updated contact information.

The completed application/renewal forms may be mailed to:

THE SOCIETY OF AFGHAN ENGINEERS
P.O. Box 151584, Alexandria, VA 22315, USA.

Thanks to those who have updated their membership renewal and have paid their annual membership fees.

Thanks for their generosity.

Thanks to members who have updated their membership renewal and have paid their annual membership fees. Thanks for their generosity.

THE SOCIETY OF AFGHAN ENGINEERS ORGANIZATION

SAE E-Executive Committee Members: **President:** Najim Azadzoi **Vice President:** Hamayon Ibrahim,
Treasurer: Mahmoud Samizay, **Secretary:** TBA **Manager:** TBA **Note:** TBA is acronym for (to be announced)

SAE Board of Directors-Officers: **Chairman:** A. Manan Khalid, M.S., P.E., LEED AP , **Vice-Chairman:** Jalal Masumi;
Executive Director: Gul Afghan Saleh

Members SAE Board of Directors: Wahed Hassani, Sharif Hossainy, Manan Khalid, Jalal Masumi, Amanullah Mommandi, Hadi Rakin, Gul Afghan Saleh, Masood Sattari, and Zabi Zaca

SAE Past Presidents: Atiq Panjshiri, Ghulam Mujtaba, Abdul Hadi Rakin, M. Quasem Kadir, Abdul Hadi Rakin, Mohammed Hashim Rayek, Ahmad Wali Shairzay, Sohaila Sanie Shekib, and Malik Mortaza

SAE Chairpersons of Committees/Subcommittees:

- Hafizullah Wardak, Chairman -SAE eNewsletter Subcommittee,
- Wali Shairzay for Chairperson of the Capacity Building and Academic Development Subcommittee.
- Bashir Kazimee for the Chairperson of the Architecture and City Planning Subcommittees.
- Rafaat Ludin for the Chairperson of the SAE/AGA Liaison Subcommittee.
- Amin Mahmood, P.E., Chairperson of the SAE Student Subcommittee.
- Mohammad Jan Mehrzai, Chairperson of SAE Corporation Committee.
- Donya Amiri, Chairperson of the SAE Membership Committee
- Hadi Rakin, Chairperson of the Water Resource Subcommittee.

SAE Local Chapter Coordinators: A. Hamid Layan – Kabul, Afghanistan; M. Qaseem Naimi – Toronto, Canada; Najim Azadzoi – Massachusetts, Mohammad Najib Poya - Northern California; TBA - Southern California; A. Manan Khalid – New York and New Jersey, Amanullah Mommandi – Colorado; Atiq Panjshiri – Virginia and Washington DC

SAE eNewsletter Subcommittee: Subcommittee Chairman: Hafizullah Wardak

Members: A. Wahed Hassani, Ph.D.,P.E. ; A. Manan Khalid, M.S., P.E., LEED AP; Abdul Hamid Layan.

SAE eNewsletter Editorial Board: Editor –In –Chief: *Hafizullah Wardak*

Editorial Board Members: A. Wahed Hassani, Ph.D.,P.E. ; A. Manan Khalid, M.S., P.E., LEED AP; and Hafizullah Wardak.

SAE eNewsletter Regional Representatives: Abdul Hamid Layan -Kabul:

Subscribe/Unsubscribe: The subscription to the SAE eNewsletter is free. If you are not receiving the SAE eNewsletter directly and would like to subscribe, please send a note to: hwardak@comcast.net with the subject “Subscribe: SAE eNewsletter”. To unsubscribe, send a note with the subject “Unsubscribe: SAE eNewsletter”.

Disclaimer: The author, reporter, or agency of each publication, project, news, and products is included in this newsletter. Additional contact information of the authors and their agencies are available with the Editorial Board of the newsletter and may be provided upon request. The Editorial Board of the Society of Afghan Engineers, Executive Committee, Board of Directors, or any of its members are not liable for the accuracy or contents of the information. The reports and information are included as provided by the authors and agencies without any changes in the substance of the documents. The information about the agency products or services is not the SAE endorsement.

THE SOCIETY OF AFGHAN ENGINEERS MEMBERSHIP APPLICATION

Full Name: _____

Address: _____

Phone: Home: _____ Office: _____

Email: _____

Degree Level: _____ Field of Expertise: _____ Years of Experience: _____

The active members of the Society of Afghan Engineers (SAE): Please mark (X) the appropriate box related to your address and other contact information.

- Yes, the above is a change in address or contact information.
- No, the above address is the same as recorded on the SAE's current membership list

Please mark (X) the appropriate box if you are submitting this application to join as a new member.

- A Regular member: I have at least four (4) years of architectural or engineering education.
- Associate member: I have at least two (2) years of architectural or engineering education

The SAE is a 501(c) (3) non-profit organization.

Amount of Annual 2023 Membership: \$60.00

Donation: -----

Total: -----

Suggestion and comments: _____

Please send your check or money order payable to the Society of Afghan Engineers.

THE SOCIETY OF AFGHAN ENGINEERS
P.O. Box 151584, Alexandria, VA 22315, USA.

SAE Bank Account Information:
Account Name: **Society of Afghan Engineers**
Bank Name: **BB&T**
Routing # **051404260**
Account # **0005139262982**
Bank Address:
7915 HENESKA LOOP
ALEXANDRIA, VA 22315-0000

MEMBERSHIP APPLICATION

(SAE Members Living in Afghanistan)

Full Name: _____

Address: _____

Occupation: _____

Place of Work: _____

Phone: Work: _____ WhatsApp: _____

Email: _____

Degree Level: _____ Field of Expertise: _____ Years of Experience: _____

The active members of the Society of Afghan Engineers (SAE): Please mark (X) the appropriate box related to your address and other contact information.

Yes, the above is a change in address or contact information.

No, the above address is the same as recorded on the SAE's current membership list

Please mark (X) the appropriate box if you are submitting this application to join as a new member.

A Regular member: I have at least four (4) years of architectural or engineering education.

Associate member: I have at least two (2) years of architectural or engineering education

The SAE is a 501(c) (3) non-profit organization.

Annual Membership: SAE Members Living inside Afghanistan are exempt of annual membership (**FREE Membership**).

Suggestion and comments:

THE SOCIETY OF AFGHAN ENGINEERS

P.O. Box 151584, Alexandria, VA 22315, USA.

Website: www.afghanengineers.org